

## LANDRIDER ACCESSORY KIT

THANK YOU FOR YOUR ORDER FOR THE LANDRIDER ACCESSORY KIT.

### **Included are:**

1. Water Bottle
2. Water Bottle Cage
3. Pump and Pump Holder that includes two extra 4 mm long Allen bolts.
4. Red Rear Safety light which includes two AA Batteries and two optional attachment brackets (one for seat stay and one for seat post)
5. Head Light which includes 4 AA size Batteries and bracket to attach to Handlebar.

### **PUMP HOLDER/WATER BOTTLE CAGE ATTACHMENT**

The Pump Holder is designed to mount on the frame Down Tube (top of Down Tube for men's model and bottom of Down Tube for women's model). **It is recommended that you turn the women's bike over so it is resting on the Seat and Handlebar.**

**Step 1:** Remove existing Allen Bolts on the Down Tube.

**Step 2:** Install the Water Bottle Cage and Pump Holder using the 4mm Allen Bolts in the Down Tube.

**Step 3:** Remove Pump from Pump Holder and on men's bike place Pump Holder under Water Bottle Cage with Pump Holder to left and facing up. **On women's bike face Pump Holder out to the right and away from cables.**

**Step 4:** Attach to the Down Tube using the 4 mm Allen bolts.

FIG. 1

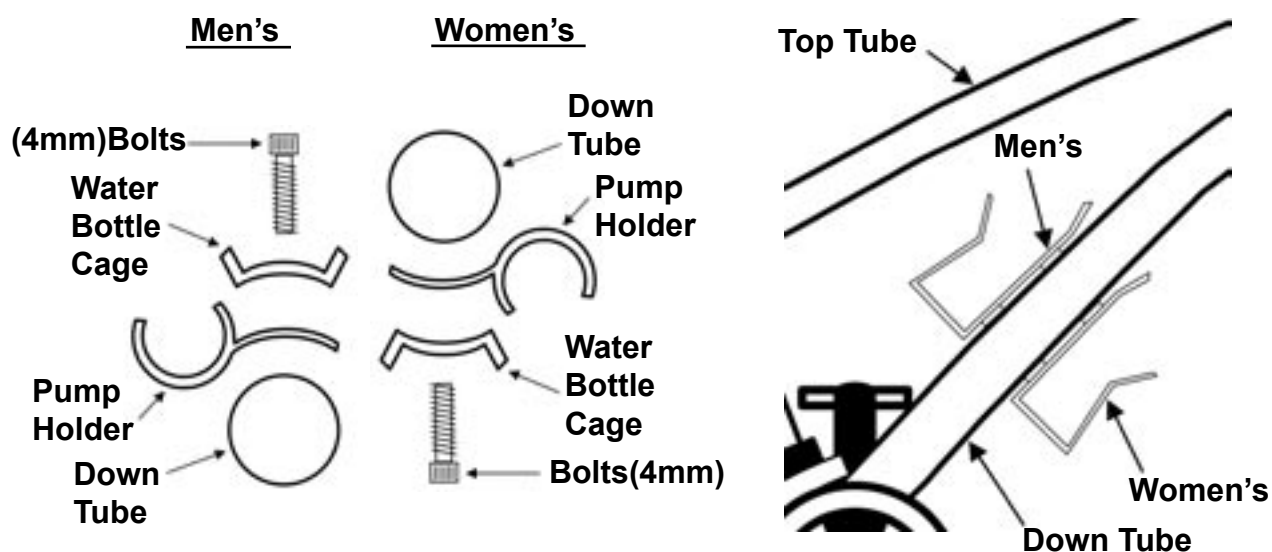

**Step 5:** Attach Water Bottle and Pump

## **SAFETY LIGHT ATTACHMENT**

There are 2 Brackets offered, one for attachment to Seat Stay (frame section from seat area to center of Rear Wheel) and one for the Seat Post.

We recommend using the Seat Post Mounting Bracket unless you need to lower the Seat Post all the way down. In which case you may want to use Seat Stay Mounting Bracket.

**Step 1:** Use a coin to open from side. Insert two AA Batteries.

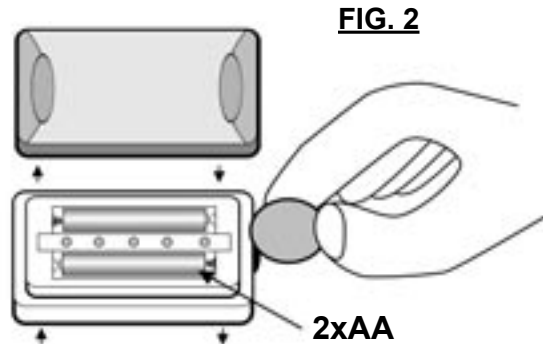

### **OPTION A: SEAT POST ATTACHMENT**

**Step 2A:** Separate Bracket and Holder (See FIG. 3).

**Step 3A:** Add two Rubber Inserts into Bracket and place Bracket around Seat Post.

**Step 4A:** Attach Holder and tighten with screw.

**Step 5A:** Slide Safety light into Holder until it snaps into place.

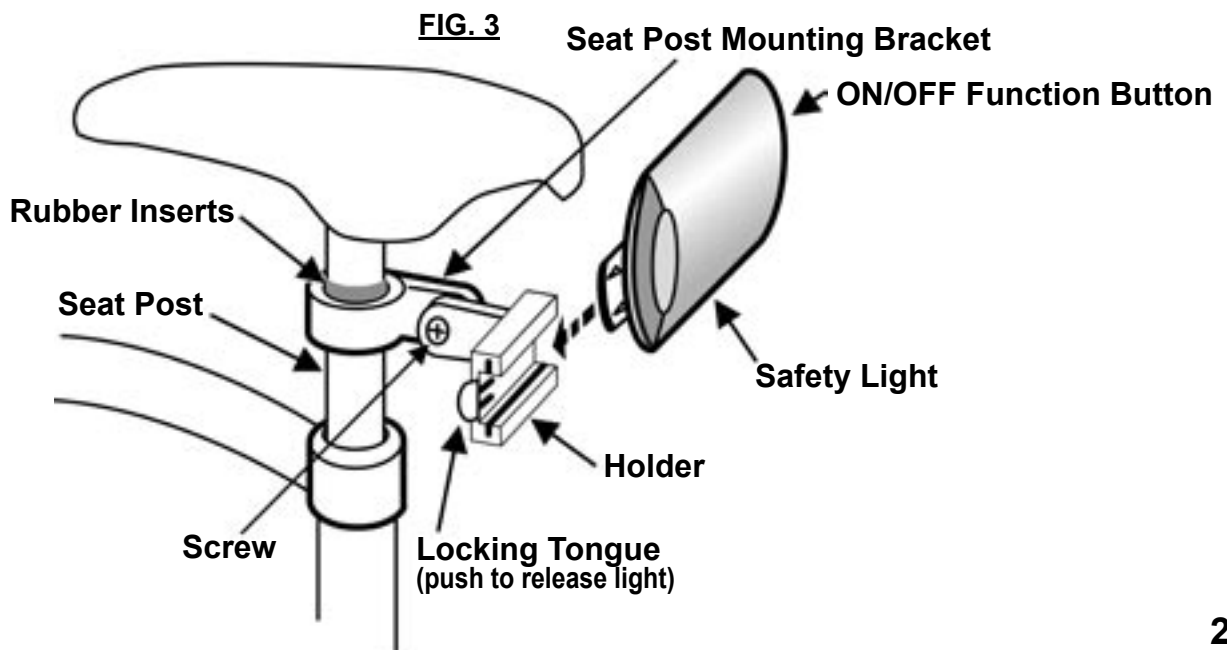

## **OPTION B: SEAT STAY ATTACHMENT**

**Step 2B:** You will need to use the screws and Safety Light Holder that was shipped attached to the Seat Post Bracket.

**Step 3B:** Attach Bracket to left Seat Stay so Bracket insert nut is facing the spokes.

**Step 4B:** Attach Safety Light Holder to Bracket so Locking Tongue is facing up. Tighten Screw.

**IMPORTANT:** Holder must be on outside of the bike so Safety Light will not interfere with the wheel.

**Step 5B:** Attach Safety Light from the top.

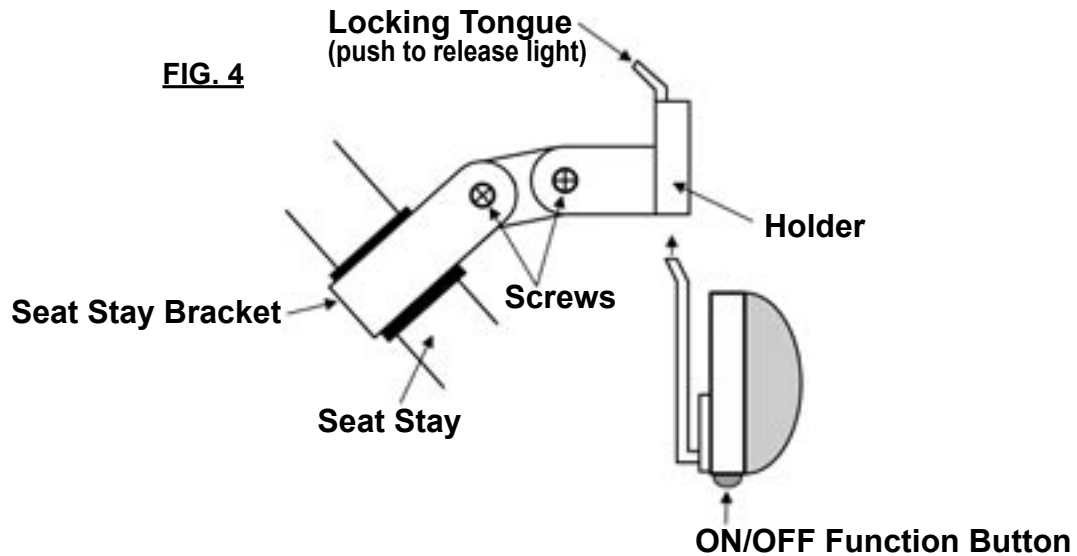

## **FRONT LIGHT ATTACHMENT**

The Front Light is designed for attachment to the Handlebar.

**Step 1:** Remove screw from the underside of the light. Insert batteries, close top and re-tighten the screw.

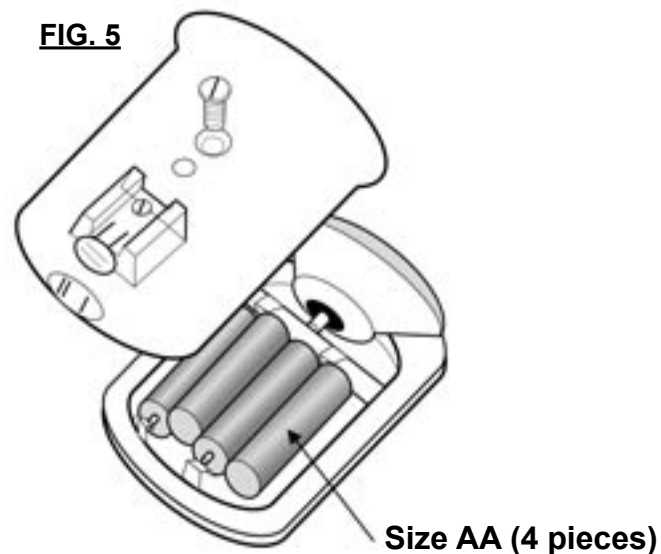

**Step 2:** Remove screw on bottom of Front Light Mounting Bracket. Using rubber spacer attach Bracket to Handlebar close to the Stem (center of Handlebar on the left side) and tighten.

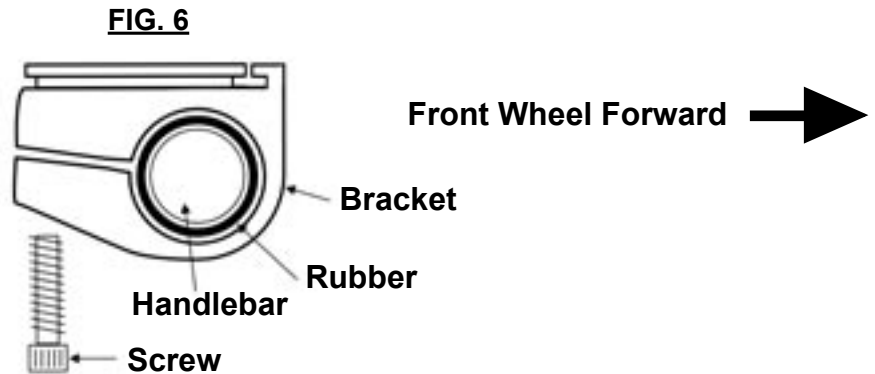

**Step 3:** Slide Light on towards front wheel until it snaps into place. Remove by pushing down on tongue.

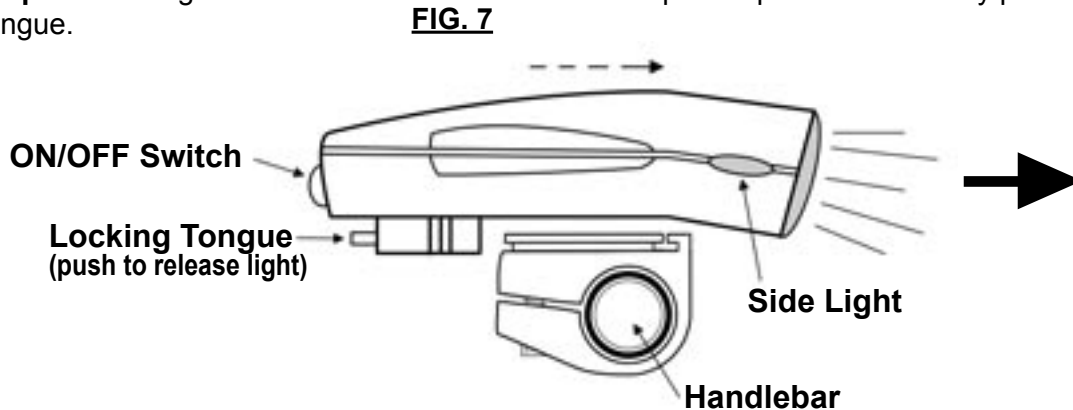

## USING THE ACCESSORIES

**Rear Safety Light:** There are 6 functions (different flashing sequences). Push yellow button on end of safety light. (See FIG. 3 and 4).

**Front Head Light:** Push gray button on back to turn on or off. (See FIG. 7).

**Pump:** The first time you try to attach the Pump to the tire valve, it may be a little difficult. Move the Pump side to side on the valve, while pressing the pump hard on valve, when tight, flip clamp lever

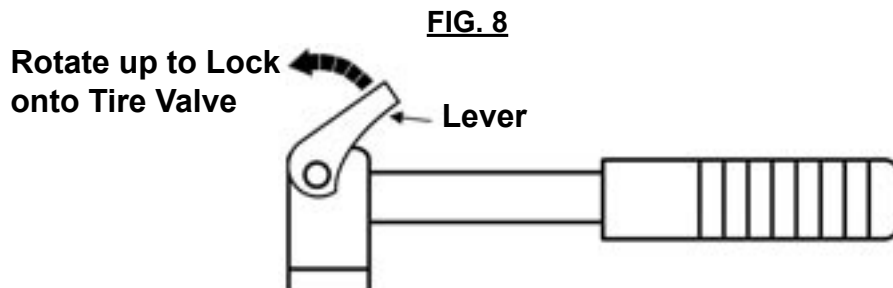

Thank You.

closed and begin pumping. (See FIG. 8).

If you have any questions, please call LandRider at 1-800-945-5335 or contact us at [service@landrider.com](mailto:service@landrider.com).